

AiM User Guide

Kit EVO4S, SOLO 2/SOLO 2 DL
for Aprilia – RS660
from 2020

Release 1.00



KIT





1

Models and years

This manual explains how to connect EVO4S and SOLO 2 DL to the bike engine control unit (ECU).

Compatible models are:

- Aprilia – RS660 from 2020

Warning: for these models/years AiM recommends not to remove the stock dash. Doing so will disable some of the bike functions or safety controls. AiM Tech srl will not be held responsible for any consequences that may result from the replacement of the original instrumentation cluster.

2

Kit content and part numbers

AiM developed a specific installation bracket for SOLO 2/SOLO 2 DL and a connection cable to the ECU for EVO4S/SOLO 2 DL.

2.1

Bracket for SOLO 2/SOLO 2 DL

Part number for **SOLO 2/SOLO 2 DL** installation bracket for **Aprilia RS 660** – shown below – is: **X46KSARSV40**.

Installation kit contains:

- 1 bracket (1)
- 1 allen screw with rounded head M8x45mm (2)
- 2 allen screws with flat head M4x10mm (3)
- 1 toothed washer (4)
- 1 rubber dowel (5)



2.2 AiM cable for EVO4S/SOLO 2 DL

Part number for **EVO4S/SOLO 2 DL** connection cable for **Aprilia RS660** – shown below – is: **V02589090**.

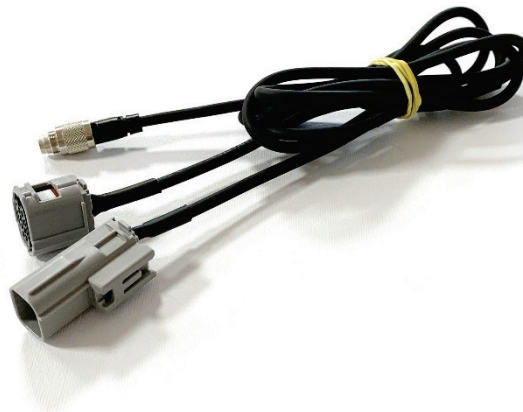

Following image shows the cable constructive scheme:

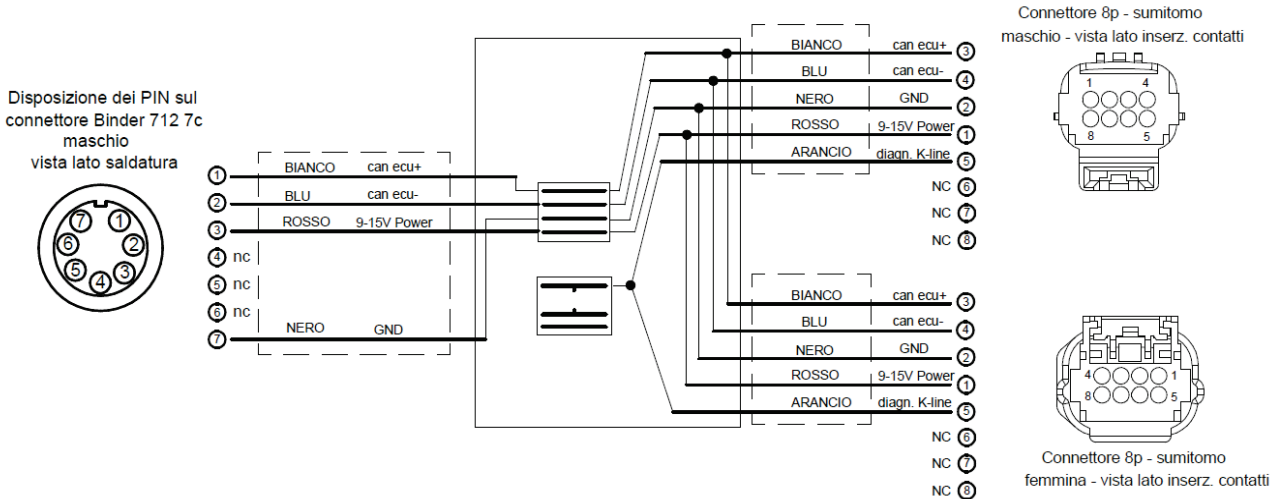

Installation bracket and connection cable for SOLO 2 DL for **Aprilia RS660** can be bought together. Part number: **V0258909CS**.

3

EVO4S/SOLO 2 DL connection

Aprilia RS660 communication line is based on CAN protocol that can be reached through the dedicated connector for “Aprilia MP/diagnostic” module connection, placed on the bike left side.



4

Configuration with Race Studio 3

Before connecting EVO4S/SOLO 2 DL to the bike ECU, set all functions using the AiM software Race Studio 3. The parameters to set in the AiM device configuration section are (“ECU Stream” tab):

- ECU Manufacturer: **Aprilia**
- ECU Model: **RSV660 Trofeo** (RS3 only)

After this first selection, enable/disable the 120Ohm resistor and the “Silent” mode on CAN Bus as follows, according to the used device:

<input type="checkbox"/>	Enable the CAN Bus 120 Ohm Resistor
<input checked="" type="checkbox"/>	Silent on CAN Bus

5

"APRILIA – RS660 Trofeo" protocol

Received channels by EVO4S/SOLO 2 DL configured with "Aprilia – RS660 Trofeo" protocol are:

CHANNEL NAME	FUNCTION
RPM	Engine RPM
Throttle	Throttle percent
Gear	Selected gear
Speed Rear	Rear wheel speed
Speed Front	Front wheel speed
TC Slip Lp	Traction control slip percent
Air Temp	Intake air temperature
Oil Temp	Oil temperature (if installed)
Engine Temp	Engine coolant temperature
Lean Angle	Lean angle
Lean Angle Sts	Lean angle status (see following values) =1 Sensor Not Available =2 Signal fault =3 Init running =4 reserved
Sensor Sts	Lean angle sensor status (see following values) =1 Undervoltage detected =2 Overvoltage detected =3 Sync underflow detected =4 Sync fault detected
LatAcc	Lateral accelerometer
LongAcc	Inline accelerometer
VertAcc	Vertical accelerometer
RollRate	Roll Rate
YawRate	Yaw Rate



PitchRate	Pitch Rate
LatAcc Status	Lateral accelerometer status (see following values)
	=1 Sensor not available
	=2 Signal fault
	=3 Init running
	=4 Reserved
LongAcc Status	Longitudinal accelerometer status (see following values)
	=1 Sensor not available
	=2 Signal fault
	=3 Init running
	=4 Reserved
VerticalAcc Status	Vertical accelerometer status (see following values)
	=1 Sensor not available
	=2 Signal fault
	=3 Init running
	=4 Reserved
RollRate Status	Roll Rate status (see following values)
	=1 Sensor not available
	=2 Signal fault
	=3 Init running
	=4 Reserved
YawRate Status	Yaw Rate status (see following values)
	=1 Sensor not available
	=2 Signal fault
	=3 Init running
	=4 Reserved
PitchRate Status	Pitch Rate status (see following values)
	=1 Sensor not available
	=2 Signal fault
	=3 Init running
	=4 Reserved



Roll Angle	Roll angle
TInj Prog1	Injection time advance
Battery Volt	Battery voltage
ECU Alarm	ECU alarm flags (see following values)
	=1 Alarm ON
	=2 Alarm Urgent ON
	=3 Reserved
Oil Press High	Oil pressure (low 0; high 1)
Clutch Sw	Clutch switch
Engine Map	Engine map (1-3)
Engine Brake	Engine brake map (1-5)
ALC Enabled	ALC enabled
ALC Level	ALC Level (1 – 3)
AWC Level	AWC Level (1 – 3)
ATC Level	ATC Level (1 – 8)
Pit Enabled	Pit enabled
Pit Speed	Pit speed set
TracDiag	Traction diagnostic
RollRateStat	Roll rate status (see following values)
	=1 IMU not available
	=2 Signal failure
	=3 Init running

Technical note: not all data channels outlined in the ECU template are validated for each manufacturer's model or variant; some of the outlined channels are model and year specific, and therefore may not be applicable.